

# Autonordic drop-forged lashing attachments



Autonordic is there when safety is required



Autonordic® 780605

HOOK

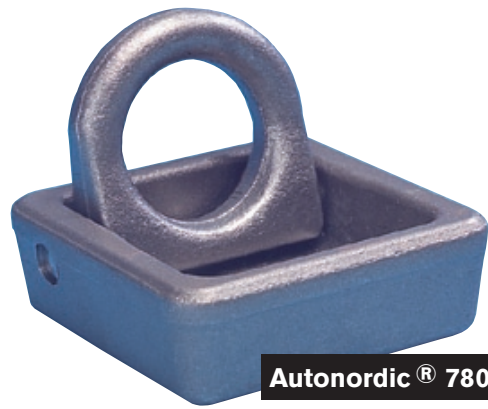

Autonordic® 780610

LASHING RING



Autonordic® 780603

HOOK



Autonordic® 780309

HOOK

Autonordic lashing attachments are forged for a breaking strength of 6 tons.



# Autonordic drop-forged lashing attachments

## TECHNICAL INFORMATION

### Autonordic 780605/780610

**780605 Hook** A hook for attaching to an edge profile, front support or container walls.  
Breaking strength 6,000 kp. Weight 1.2 kg.

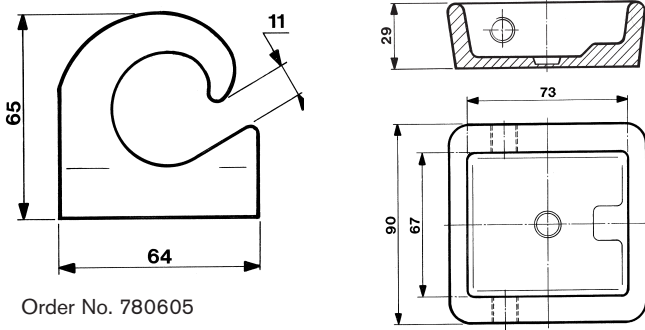

Order No. 780605

**780610 Lashing ring** Lashing ring for attaching to an edge profile, front support or container walls.  
Breaking strength 6,000 kp. Weight 1.2 kg.

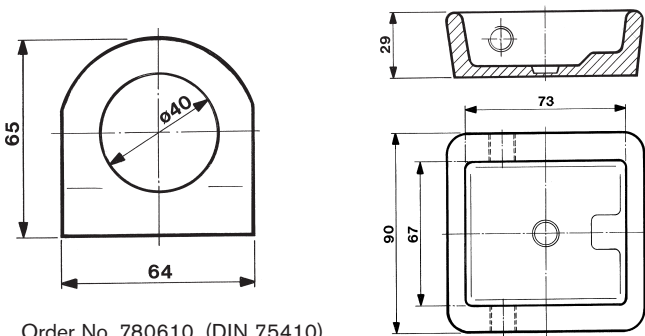

Order No. 780610, (DIN 75410)

#### Lashing angles

Both the hook and the lashing ring can cope with 6 tons at different angles.

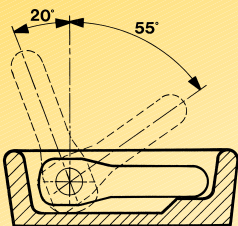

#### Clamp tying

(780603, 780605)

With a suitable triangular fitting secure locking is obtained.

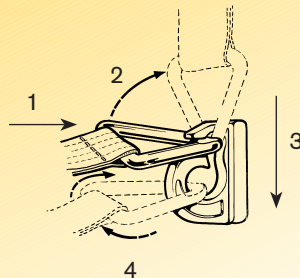

The Autonordic lashing attachments have been tested in accordance with EN 10204-3.1.B (DIN 50049)

Autonordic load safety products are origin marked and made in Sweden.

**ExTe**

Securing cargo. We invented the Concept.

ExTe Fabriks AB, SE-820 41 Färila Sweden.  
Tel: +46 (0)651 175 00. Fax: +46 (0)651 175 03.  
E-mail: info@exte.se www.autonordic.se

### Autonordic 780603/780309

**780603 Hook** Hook for welding on.  
Breaking strength 6,000 kp. Weight 0.35 kg.

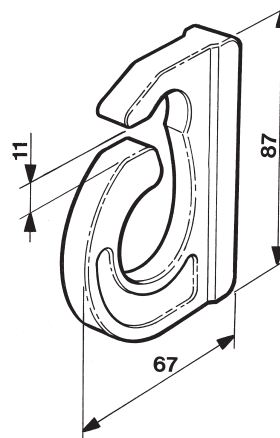

Order No. 780603



**780603 Hook** for welding on.

#### 780309 Hook

Breaking strength 6,000 kp. Weight 1.0 kg.

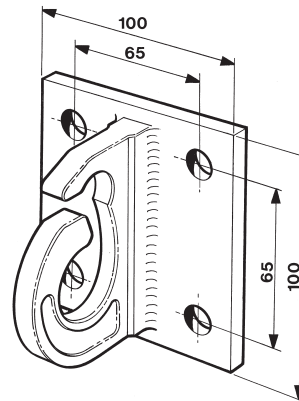

Order No. 780309



**780309 Hook** delivered with a mounting plate for bolting on. Zink-plated.

We reserve the right to make changes without prior notice.

**Note.** When mounting, follow the chassis manufacturer's instructions and authorities' requirements for strength.

Tensile tested by the Swedish National Testing and Research Institute.