

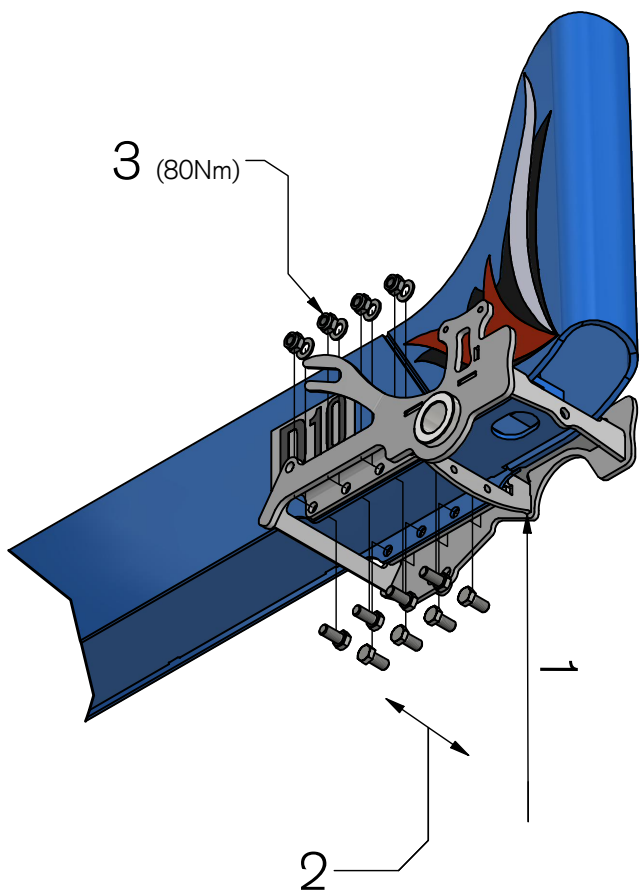





# Instruktion / Instruction / Anweisung

## D-Serien / D-Series / D-Serie

Montering av fäste på stomme / Mounting of attachment on bolster / Befestigung des Aufsatzes am Schemelkörper  
Nedan visas ett vänsterfäste / Left version illustrated below / Linke Version unten abgebildet



Sats / Kit / Bausatz	
Part No. 800853 / 800854	
Förmonterat / Preassembled / Vormontiert	
1	 x1
	 x1
	 x1
2	 x8
3	 x14
	 x8

# ExTe

Securing cargo. We invented the Concept.

Nedan visas ett vänsterfäste / Left version illustrated below / Linke Version unten abgebildet

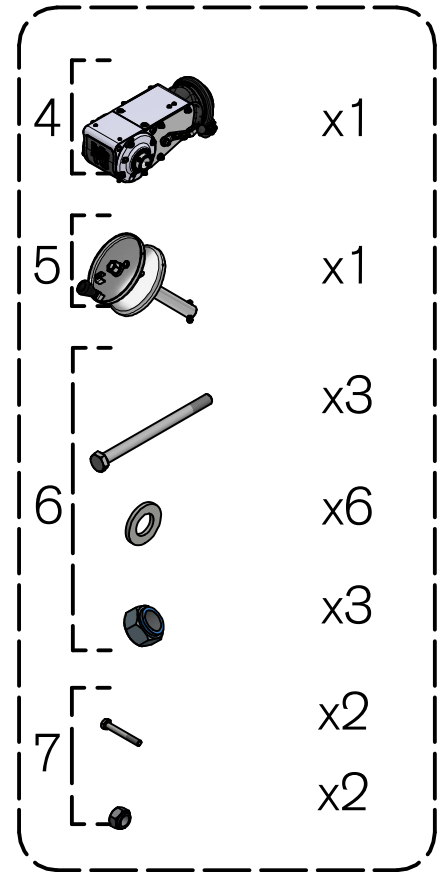
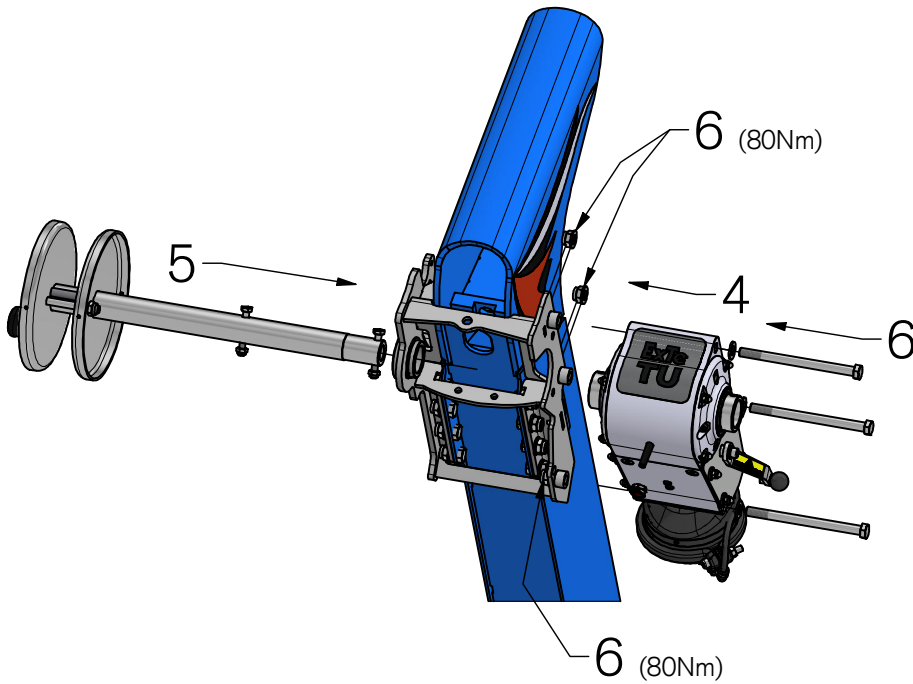

5.  
Placera trummans axel i spännarens axel/ Place the shaft of the drum in the shaft of the tensioner/  
Setzen Sie die Welle der Trommel in die Welle des Spanners ein

6.  
Dra åt spännarens tre skruvar med maximalt 80Nm/  
Tighten the tensioner's three screws with a maximum of 80Nm/  
Ziehen Sie die drei Schrauben des Spanners mit maximal 80 Nm . an

6.1  
Kontrollera att trumman (5) går att föra fram och tillbaka i spännarens axel även efter åtdragning av spännarens skruvar/  
Check that the drum (5) can be moved back and forth in the shaft of the tensioner even after tightening the screws of the tensioner/  
Prüfen Sie, ob sich die Trommel (5) auch nach dem Anziehen der Schrauben des Spanners in der Welle des Spanners hin und her bewegen lässt

7.  
Dra skruvarna max. 25Nm/ Tighten the screws maximum 25Nm/ Ziehen Sie die Schrauben mit maximal 25 Nm . an

7.1  
Om det uppstår problem vid monteringen, kontakta ExTe support och eftermarknad/  
If problems occur during installation, contact ExTe support and aftermarket/  
Wenn während der Installation Probleme auftreten, Wenden Sie sich an den ExTe-Support und den Aftermarket  
mail: [support@exte.se](mailto:support@exte.se)

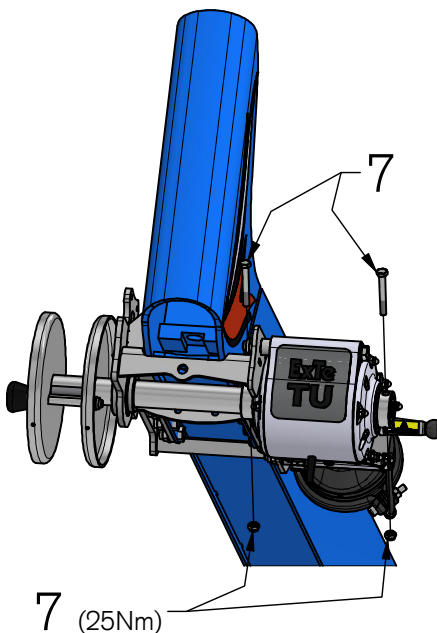

# ExTe

Securing cargo. We invented the Concept.

ExTe Fabriks AB, SE-820 41 Färila Sweden. Tel: +46 (0)651 175 00. Fax: +46 (0)651 175 03. E-mail: [info@exte.se](mailto:info@exte.se) [www.exte.se](http://www.exte.se)